



HF77-0001 HFM-M S MSMP BG04-1

**Contacting
4-pole HFM-Male**

NEW

Centers (mm/mil)	4,00 / 157
Current (Circular)	0,5 A
Current (Internal)	0,1 A
Impedance [Z]	50 Ohm
Frequency	12 GHz
Temperature	-20°C...+80°C

Spring Force (cN ±20%)		
	Preload	Nominal
Internal Cont.	95	120
Circular Cont.	230	420

Travel (mm)		
	Nominal	Maximum
Internal Cont.	0,5	1,8
Circular Cont.	2,0	2,8
Wrench Size	-	

Materials and Plating	
Internal Cont.	BeCu, gold plated
Circular Cont.	BeCu, gold plated
Barrel	Brass, gold plated
Spring Internal Cont.	Music Wire, gold plated
Spring Circular Cont.	Stainless steel, unplated

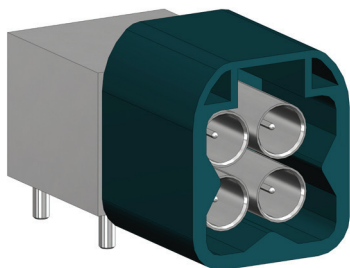
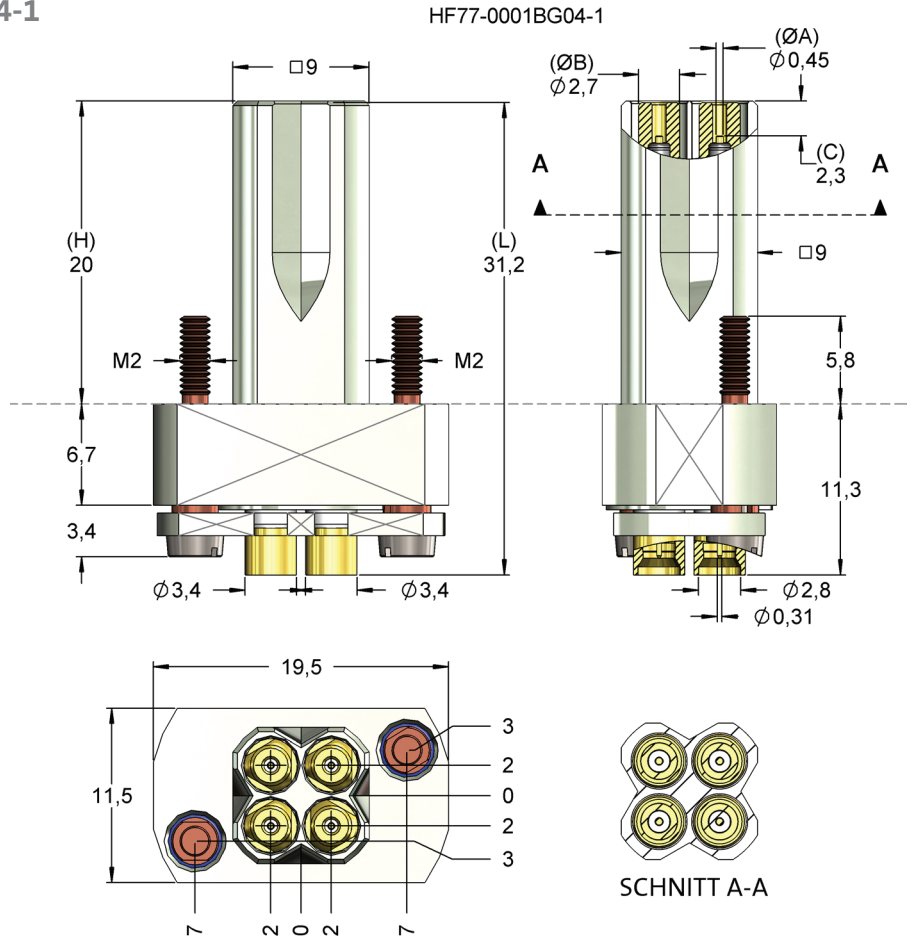

HFM-Male (4-pole)

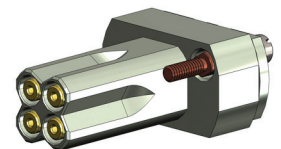
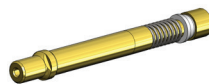

The block can be mounted using the flange. Cable connection with standard connector Mini SMP female. In the HF77-0001BG04-1 the HF7716B0001G530 was installed four times.

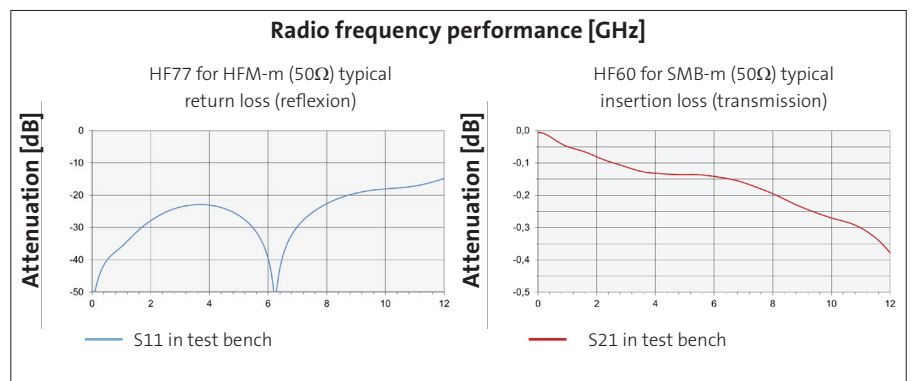

Order Code	Description	Sensepin	Tip Style	Ø A	Ø B	C	H	L	Version
HF77-0001BG04-1	HF77-0001 HFM-M S MSMP BG04-1		16	0,45	2,70	-2,30	20,00	31,20	-



HF77

NEW

Assembly of the RF-probe

The probe variants of the HF77 can be mounted on or through a mounting plate.

Variant: Single plug

Here the probe can simply be screwed to the mounting plate by means of a flange.

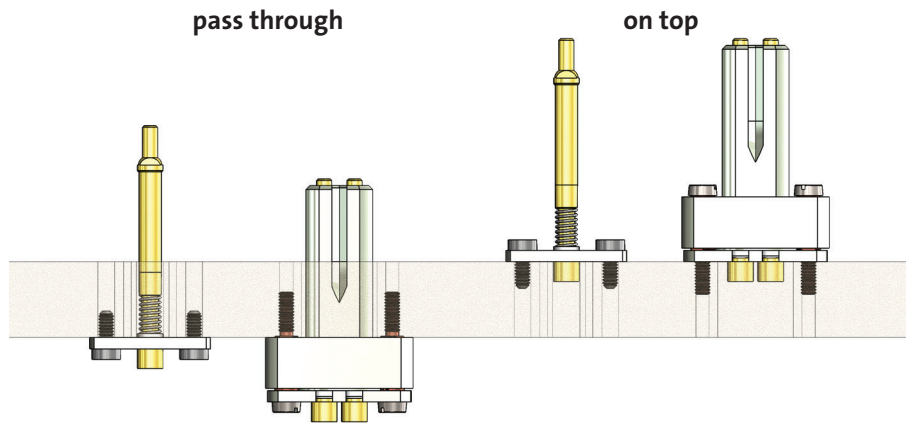

Variant: 4-fold plug

Step 1

The module housing [1] is screwed onto the mounting plate using the threaded pins [2].

Step 2

The four HF probes [3] are hooked into the flange provided for this purpose and inserted into the housing [1].

Step 3

With the M2 screws [4] the 4-fold assembly [3] is connected to the assembly-housing [1] screwed tight.

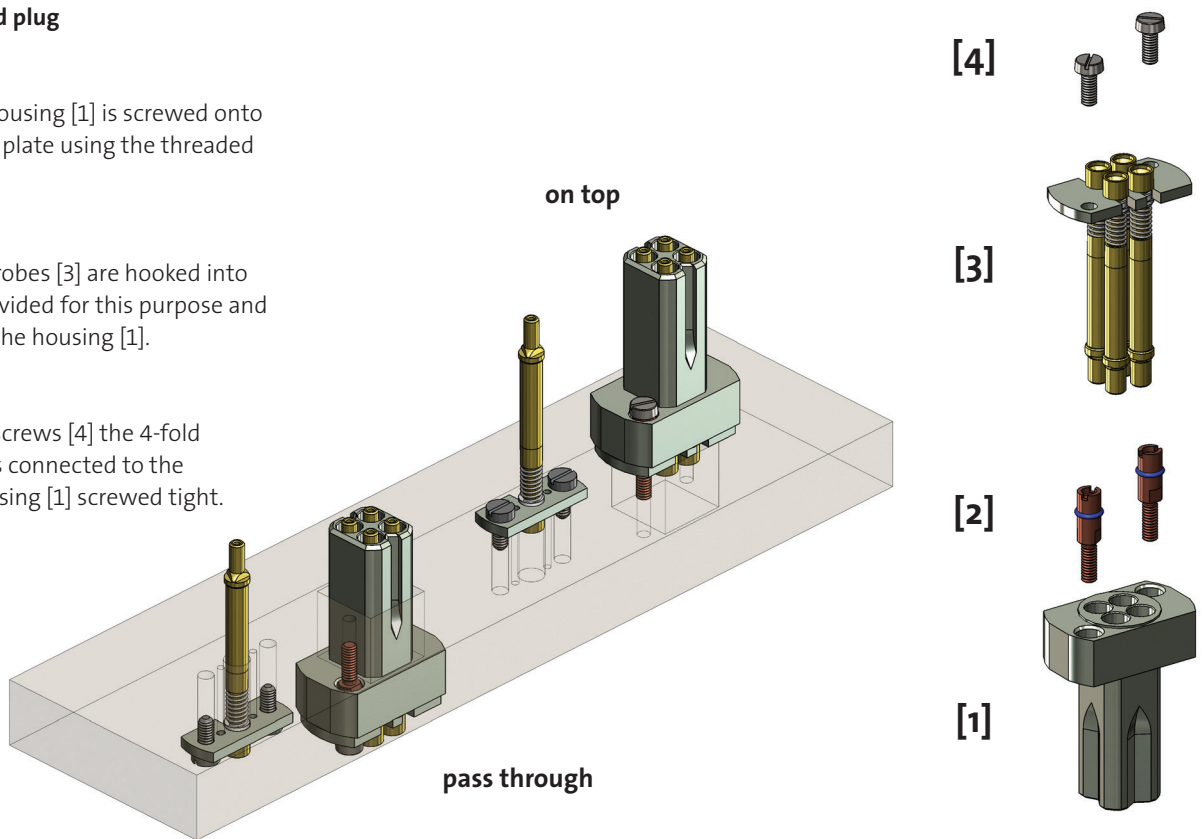

Change of RF-probe

With the release tool FUWZ-001 the pin can be released from the flange. The chamfered tip of the tool is inserted between the flange and the synthetic stop of the spring. Then the spring can be pressed in with the tool and the probe can be pulled out of the groove of the flange. In the same way, the Mini SMP cable connection can be simply pulled off without pulling on the cable.

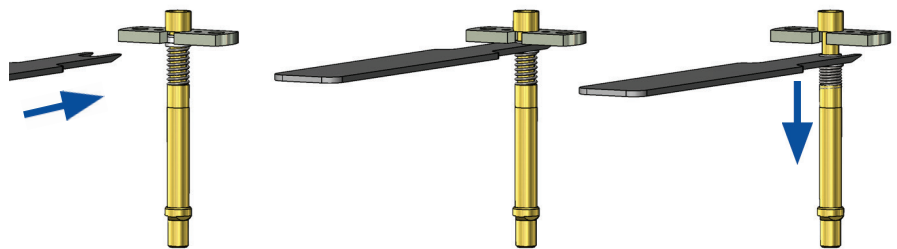



Floating bearing of the radio frequency block HF77

Description Structure

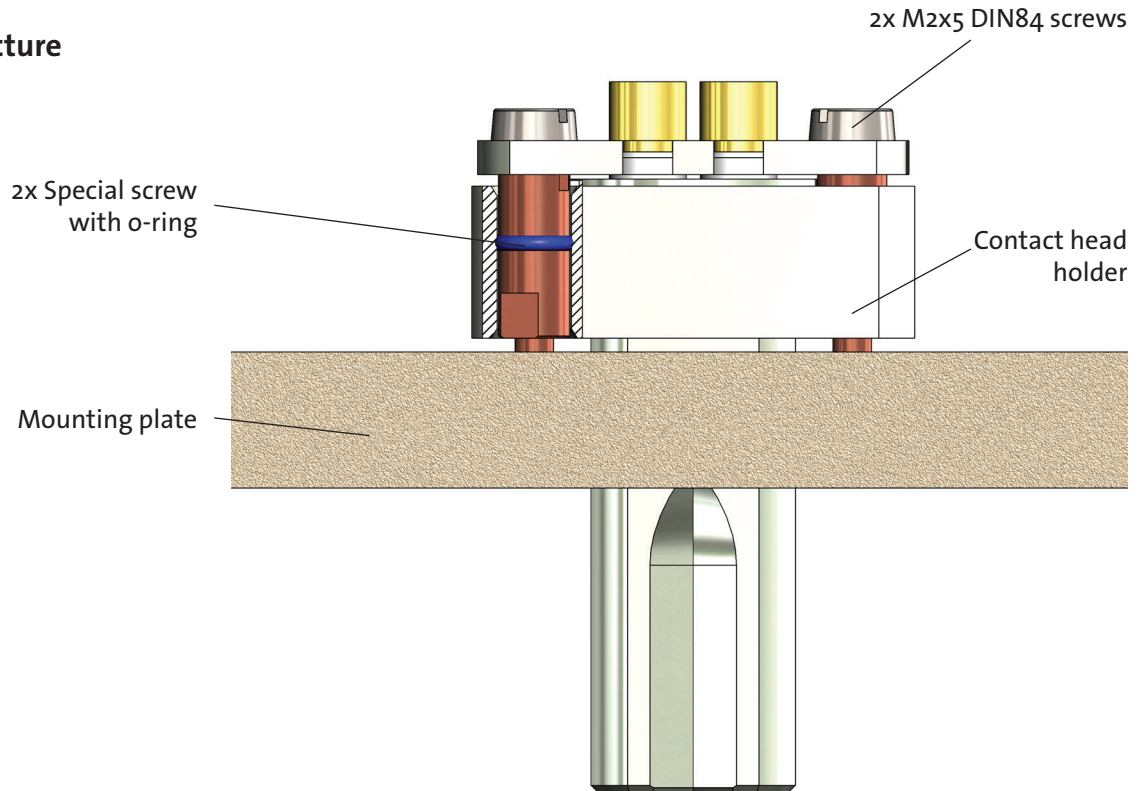

functional principle

The collar length of the special screws is slight longer than the collar of the Contact head holder.

Because of the fixed O-ring at the special screw, the Contact head holder is floating and can compensate positional tolerances that may occur.

In addition, each RF-probe is able to float separately inside the Contact head holder.

