

HIGH CURRENT PROBES



HC10

High current probe up to 100 A for Ø6mm round pins with finger protection

Centers (mm/mil)	12,0 / 472
Current	100 A
R typ	<1 mOhm
Temperature	-40°C...+200°C (H)

Spring Force (cN ±20%)

Version	Preload	Nominal
Standard	1400	2400

Travel (mm)

Version	Nominal	Maximum
Standard	4,0	5,0
Thread (M)	M10x1	
Wrench Size	10	
Pointing Accuracy	±0,10 mm	

Materials and Plating

Plunger head	BeCu, gold plated
Plunger	Brass, silver plated
Barrel	Brass, unplated
Spring	Stainless steel, unplated

Accessories

Insertion tool probe	FWZHC10(T)
----------------------	------------

Drill Size (mm)

HC10	M10x1
------	-------

Projection Height (mm)

HC10	28,2
------	------

HC10A52B240G13060

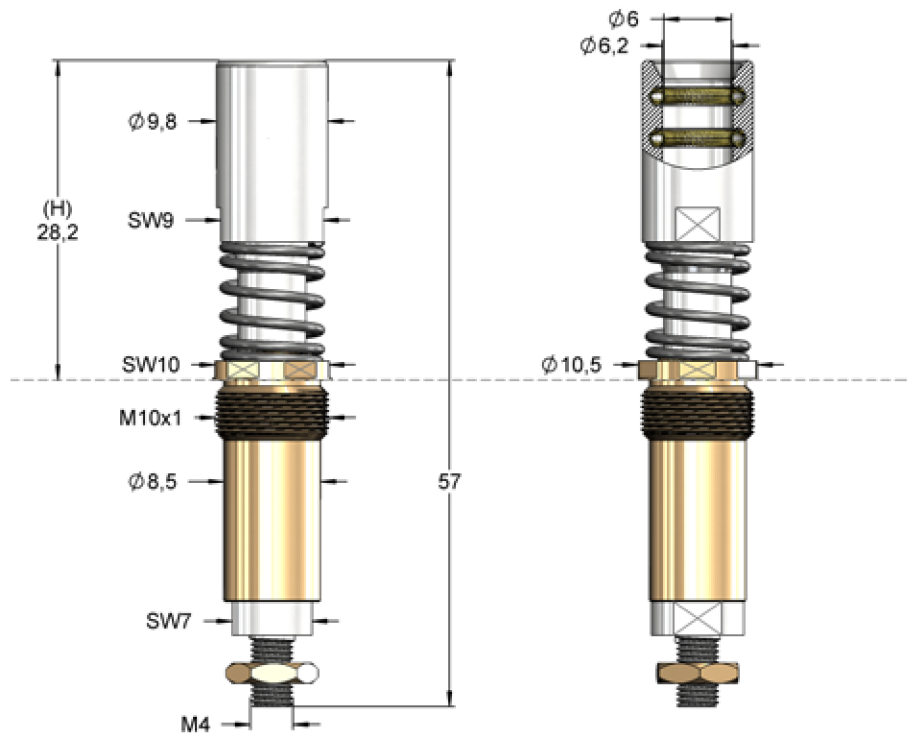

M1:1



The challenge in the field of e-mobility is a scratch-free contacting of a round pin with finger protection on the end face. The HC10 is the perfect solution for use with pin Ø6.0 mm.

Recommended cable cross-section: 16 mm².

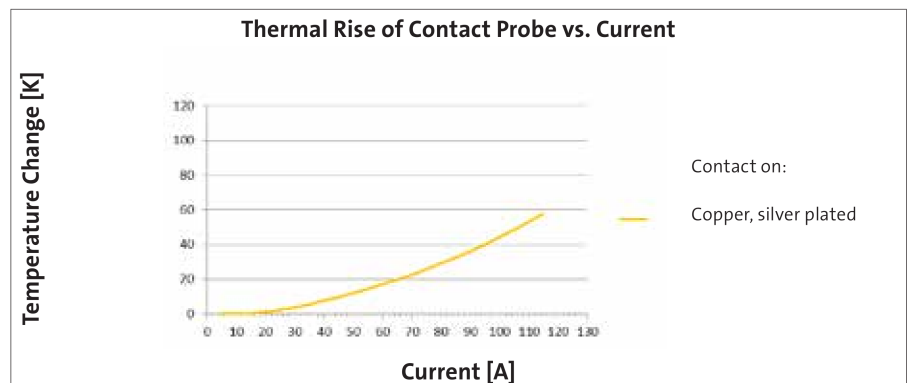

Order Code	Tip Style	Number	Material	Ø in mm	Plating	Mounting with
HC10A52B240G13060		52	B	9,80	A	M4