

HIGH CURRENT PROBES



HC09

High current probe up to 60 A for Ø4mm round pins with finger protection

Centers (mm/mil)	8,0 / 314
Current	60 A
R typ	<2 mOhm
Temperature	-40°C...+200°C (H)

Spring Force (cN ±20%)

Version	Preload	Nominal
Standard	1400	2400

Travel (mm)

Version	Nominal	Maximum
Standard	4,0	5,0
Thread (M)		10x1
Wrench Size		10
Pointing Accuracy		±0,10 mm

Materials and Plating

Plunger head	Brass, gold plated
Plunger	Brass, gold plated
Barrel	Brass, unplated
Spring	Stainless steel, unplated

Accessories

Insertion tool probe	open-end wrench SW 6,0
----------------------	---------------------------

Drill Size (mm)

HC09	M5x0,5
------	--------

Projection Height (mm)

HC09	24,2
------	------

HC09A52B100G08040

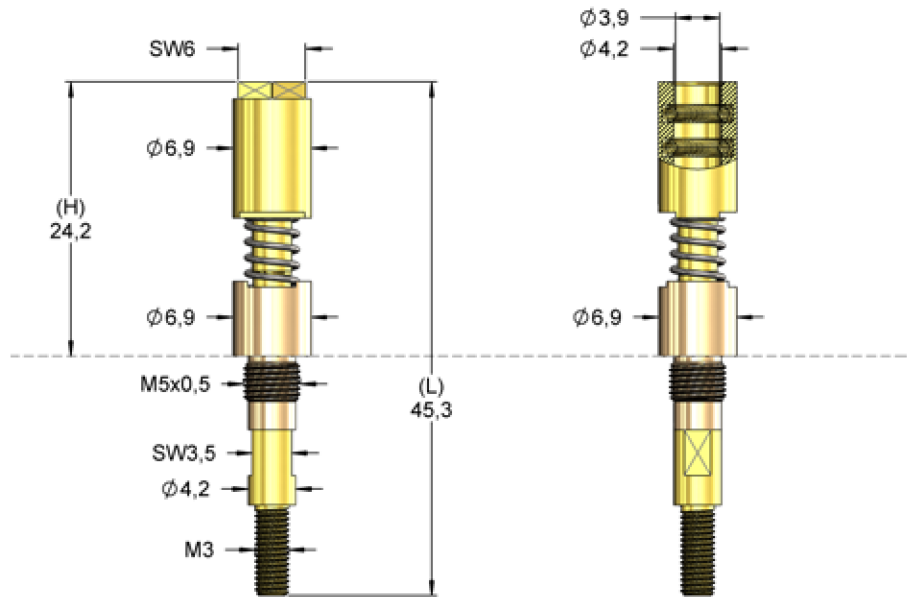

M1:1



The challenge in the field of e-mobility is a scratch-free contacting of a round pin with finger protection on the end face. The HC09 is the perfect solution for use with pin Ø4.0 mm.
Recommended cable cross-section: 16 mm².

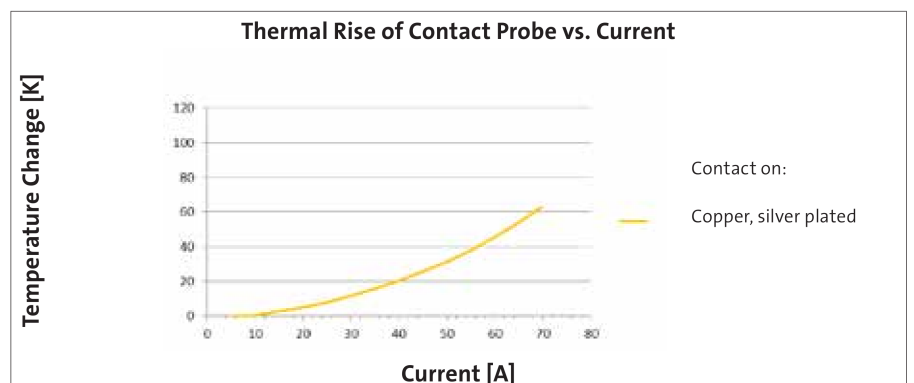

Order Code	Tip Style	Number	Material	Ø in mm	Plating	Mounting with
HC09A52B100G08040		52	M	6,90	G	M3