

HIGH CURRENT PROBES



HC02

High current block
up to 100 A
for Scratch contacting

Centers (mm/mil)	12,0 / 472
Current (Power)	100 A
Current (Sense)	1,0 A
R typ	<2 mOhm
Temperature	-40°C...+200°C (H)

Spring Force (cN ±20%)		
Version	Preload	Nominal
Sense pin	70	150
Circular cont.	3x 170	3x 600

Travel (mm)		
Version	Nominal	Maximum
Sense pin	4,3	6,4
Circular cont.	4,0	5,0
Thread (M)		4,0
Wrench size		3,0/10,0

Materials and Plating	
Plunger	BeCu, gold plated
Barrel	Brass, gold plated
Spring holder	Stainless steel, gold plated
holder	Brass, silver plated

Accessories	
Insertion tool holder	FDWZ-860C009
Screw-in tool sense pin	FWZ730S1 (T)
Screw-in tool probe	FWZ733S2 (T)

Drill Size (mm)	
Receptacle with knurl	10,00 - 10,05

Projection Height (mm)	
HC02	12,8

Suitable for:

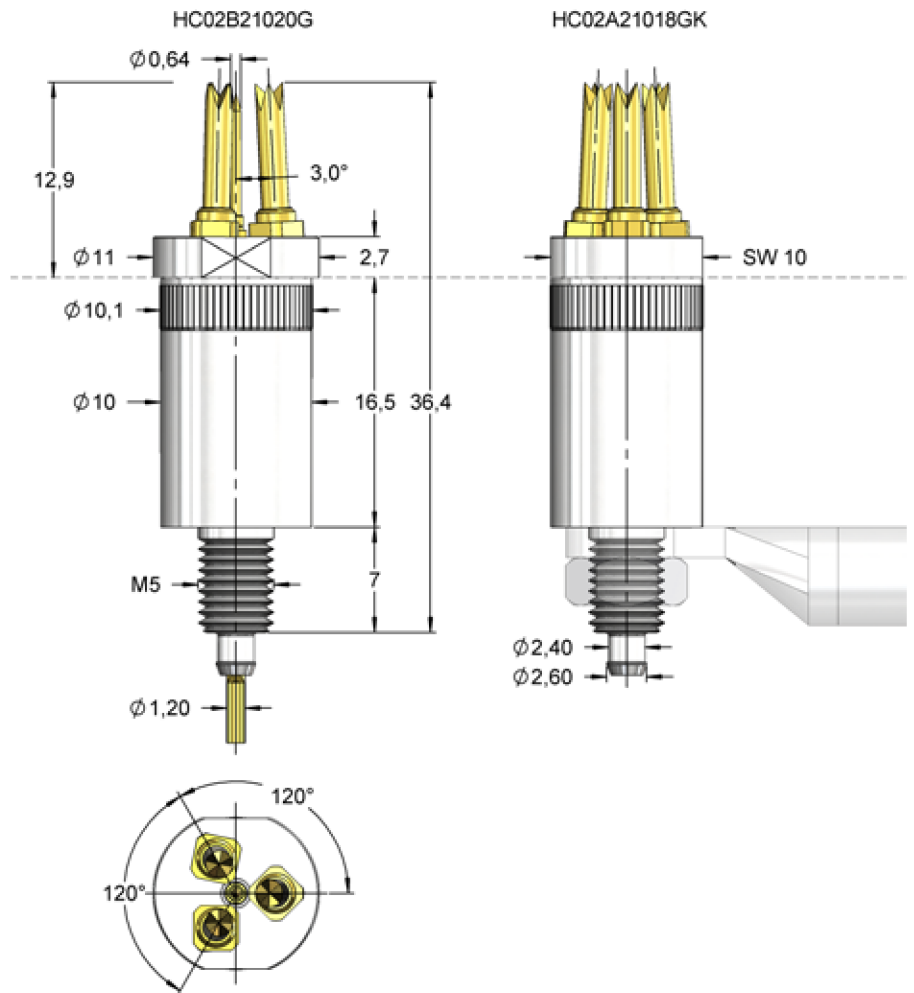

A ring eye or a cable lug can be fixed to the M5 thread by a lock nut. The built-in threaded probes F733 can be changed with the screw-in tool FWZ733S2T. The high current block is available either as a pure scratch contact or with sense pin. Connection recommendation Cable diameter 25 mm².

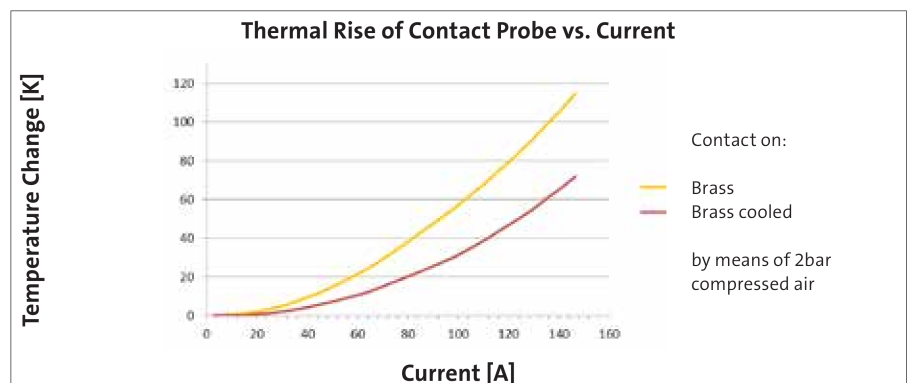

Order Code	Tip Style	Bezeichnung	Sense	Sensor	Mounting with	Screw-in Tool
HC02A21018GK		3x F733 KF21	x	-	M5	FWZ733S2 (T)
HC02B21020G		3x F733 KF21	-	F175 KF18	M5	FWZ733S2 (T)