

GKS 747 M

Screw-in Non-Rotating Test Probe with Continuous Plunger

Grid:

≥ 4,50 mm

≥ 180 Mil

Installation height with KS: 16,2 / 20,2 mm (.638 / .795)

Recommended stroke: 4,0 mm (.157)

Mounting and functional dimensions

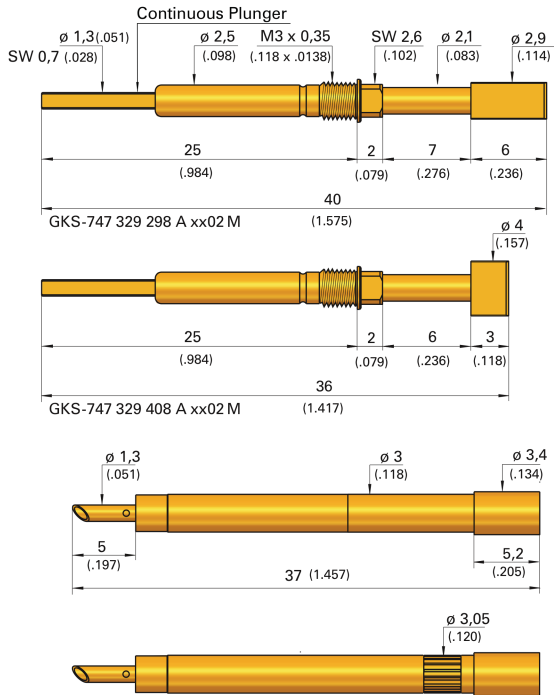

Available tip styles

Material	Tip style	Plating	Install. height with KS	
			Collar height	Install. height
3	29	A	02	20,2 (.795)
3	29	A	02	16,2 (.638)

Collar height and installation height

The installation height at the tip (dimension without KS) is determined by the collar height and the tip length (see table "Available tip styles").

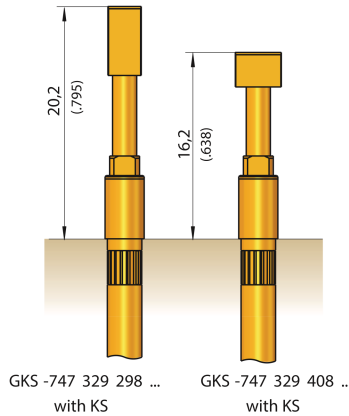

Note:

When screwing the test probe into the receptacle, the plunger is secured against rotation. The flat surface at the end of the plunger fits into the slot at the end of the receptacle.

The assembled unit is then vacuum-sealed and can therefore be used for leakage tests.

The flat surface on the plunger tip is aligned with the flat surface on the rear of the plunger.

Recommended screw-in torque:
Min.: 10 cNm / Max.: 20 cNm

Mechanical data

Working stroke: 4,00 mm (.157)
Maximum stroke: 5,0 mm (.197)
Spring force at work. stroke: 1,5 N (5.4oz); 3,0 N (10.8oz)

Materials

Plunger: Steel or BeCu, gold-plated
Barrel: Brass, gold-plated
Spring: Steel, gold-plated
Receptacle: Brass, gold-plated

Electrical data

Current rating: 8 A
R_i typical: < 30 mΩ

Mounting hole size

for **KS-747 23 M** in CEM1 and FR4: ∅ 2,99 mm (.1177)
 for **KS-747 23 M-R** in CEM1 and FR4: ∅ 3,00 - 3,02 mm (.1181 - .1189)

Operating temperature

Standard: -40° up to +80° C

Ordering example

Series	Tip material	Tip style	Tip diameter (1/100 mm)	Plating	Spring force (dN)	Collar height (mm)	Type
	3 = BeCu			A = Gold			

Test probe:

G K S 7 4 7 3 2 9 2 9 8 A 1 5 0 2 M

Receptacle:

K S - 7 4 7 2 3 M K S - 7 4 7 2 3 M - R