



## F67311B2003G065WR

### Battery Contact for Direct Soldering on PCBs

<b>Centers (mm/mil)</b>	2,54 / 100
<b>Current</b>	5,0 A
<b>R typ</b>	<100 mOhm
<b>Temperature</b>	-45°C...+200°C (H)

#### Spring Force (cN ±20%)

Version	Preload	Nominal
WR	10	65

#### Federwege (mm)

Version	Nominal	Maximum
WR	1,2	1,5

#### Materials and Plating

Plunger	see tip style
Barrel	Brass, gold plated
Spring	Stainless steel, unplated

#### Drill Size (mm)

F67311B2003G065WR	0,51 - 0,55
-------------------	-------------

#### Projection Height (mm)

F67311B2003G065WR	5,7
-------------------	-----

With Bias Design

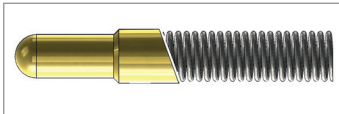

F67311B2003G065WR

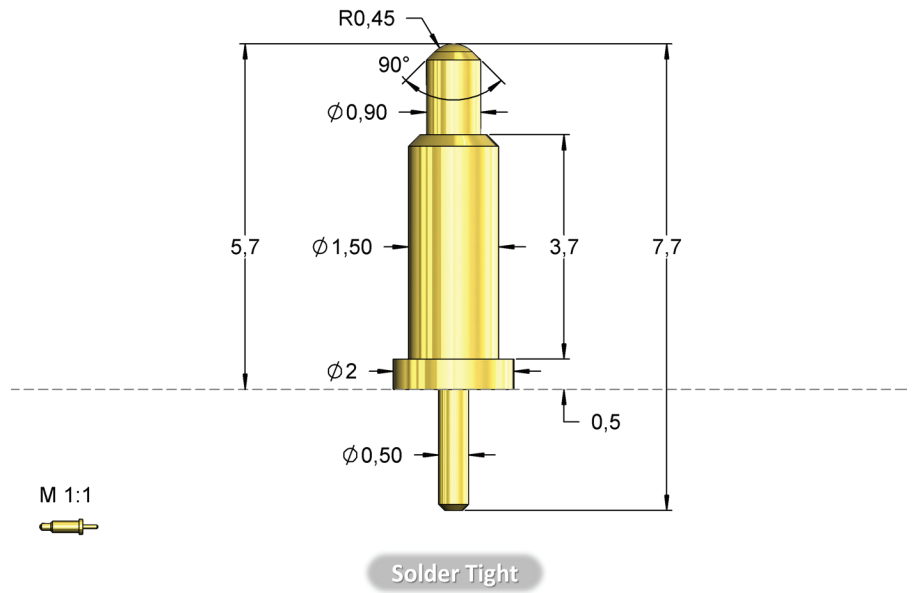

Order Code	Tip Style	Number	Material	Ø in mm	Plating	Version
F67311B2003G065WR		11	B	0,90	G	WR