

HIGH CURRENT PROBES

F340

High Current Probe 157 mil with Continuous Plunger up to 16 A, Plug-in

Centers (mm/mil)	4,00 / 157
Current	16,0 A
R typ	<10 mOhm
Temperature	-40°C...+200°C (H)

Spring Force (cN ±20%)

Version	Preload	Nominal
Standard	80	260
Standard	150	400
Standard	300	540

Travel (mm)

Version	Nominal	Maximum
Standard	6,4	8,0
Pointing Accuracy		±0,10 mm

Materials and Plating

Plunger	see Tip Style
Barrel	Bronze, unplated
Spring	Stainless steel, unplated
Receptacle	Bronze, gold plated

Accessories

Insertion tool receptacle	FEWZ-340E0
Insertion tool probe	FDWZ-100

Drill Size (mm)

F340	2,37 - 2,40
H340	2,68 - 2,69

Projection Height (mm)

H340 mit F340	22,5
---------------	------

The continuous plunger guarantees a low internal resistance and allows applications with high currents. The connection of the plunger should be realized by a flexible wire with sufficient space for the movement. The wire can also be soldered directly to the receptacle. However, this leads to a lower electrical performance.

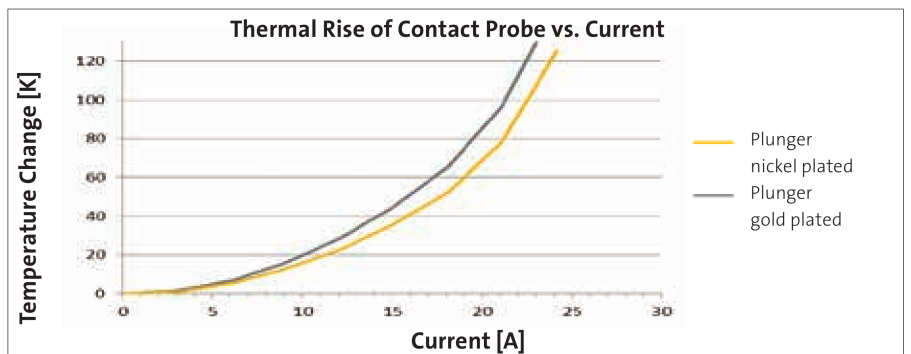
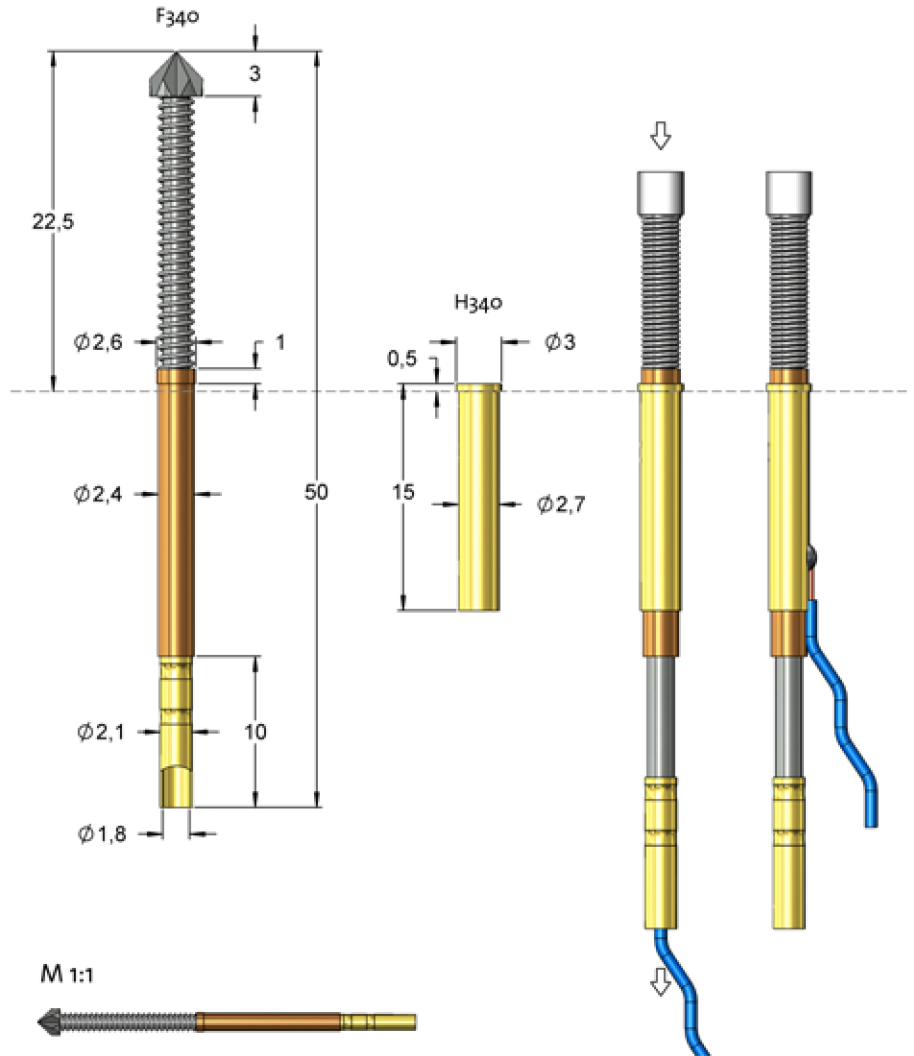

Series	Tip-Ø	Spring Force (cN)
F340	04	S
		350
		N
		260
		-
	Tip Style	Material
		Plating
		Version

Material: S = Stahl
Tip-Ø: 350 = 3,50 mm (e.g.)
Plating: L = Longtime gold plated, N = Nickel plated
Version: -
Receptacle: Order code according drawing

Tip Style	Number	Material	Ø in mm	Plating	Version
	04	S	3,50	N	-
	05	A	3,00	U	-
	05	S	3,50	L	-
	05	S	3,50	N	-
	07	S	3,50	L	-
	09	S	3,50	L	-
	17	A	3,00	U	-